

Sewing Methods Chicago Style Stitch

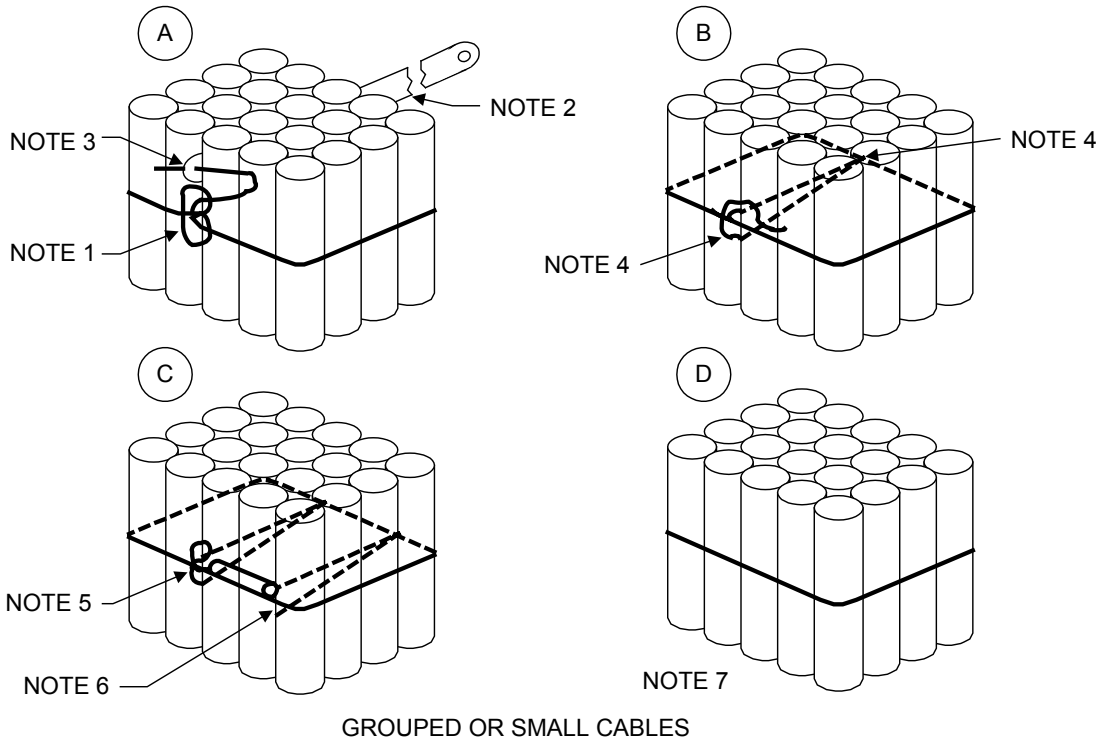
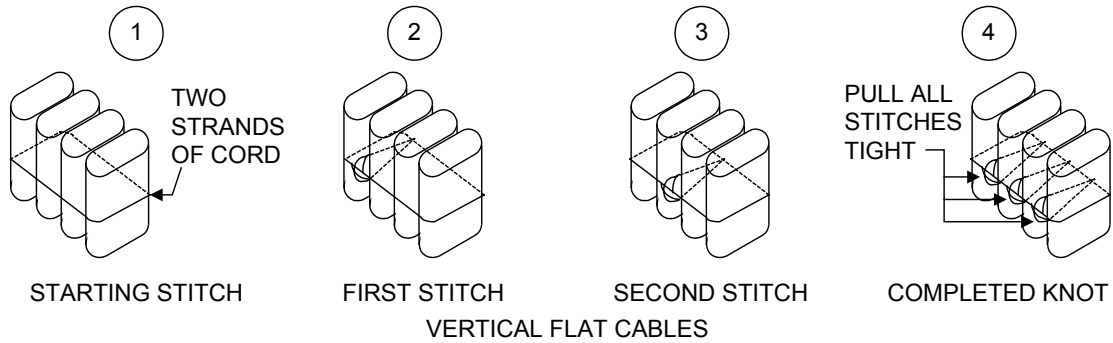

NOTES:

1. MAKE STARTING STITCH AROUND CABLES - A .
2. USE CHICAGO NEEDLE FOR PASSING TWINE BETWEEN CABLES - A .
3. HOOK END OF LACING TWINE WITH SEWING NEEDLE - PER A .
4. WHEN PASSING TWINE BETWEEN CABLES, LEAVE ENOUGH SLACK ON BOTH SIDES TO MAKE IT EASY TO GRASP THE TWINE WHEN TIGHTENING THE STITCH - PER B .
5. PULL OUT SLACK BEFORE STARTING NEXT STITCH - PER C .
6. MAKE THE LAST STITCH AS SHOWN. TIGHTEN STITCH AND DEAD END WITH A SQUARE KNOT - PER C .
7. REAR VIEW OF COMPLETED STITCH - PER D .

Figure 12 - Methods of Tying the "CHICAGO" Stitch

Sewing Methods Kansas City Style Stitch

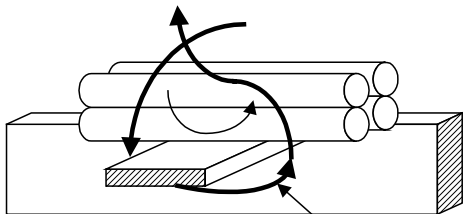

Figure 13a — NOTE 1

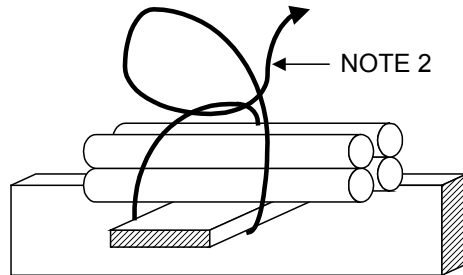

Figure 13b

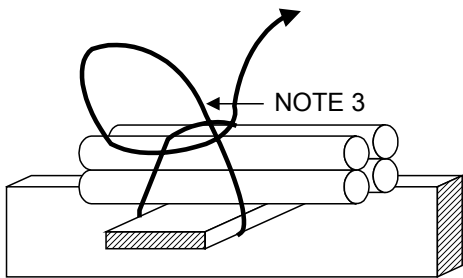

Figure 13c

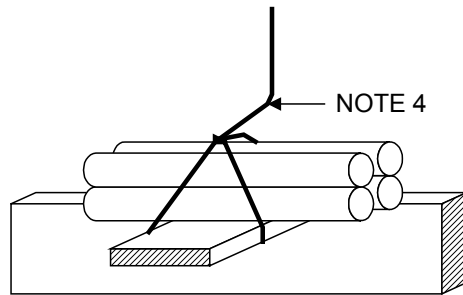

Figure 13d

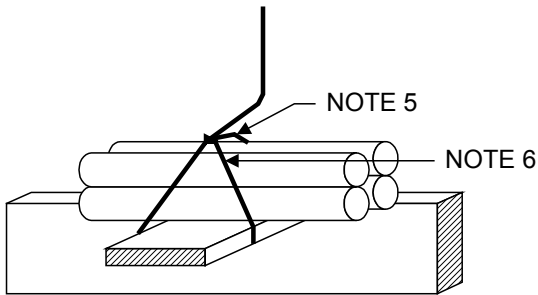
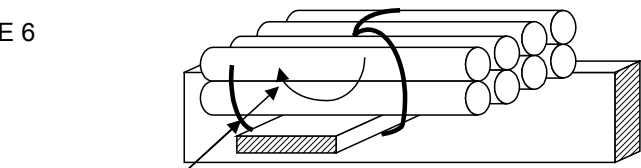

Figure 13e



NOTE 1 — Figure 13f

NOTES:

1. PLACE FREE ENDS UNDER SLAT (FIGURE 13a). THE DIRECTION UNDER THE SLAT SHALL BE REVERSED ON ALTERNATE STITCHES (FIGURE 13e AND 13f).
2. PLACE FREE ENDS OVER TWINE AND BACK THROUGH THE LOOP (FIGURE 13b).
3. TIGHTEN STITCH UNDER THE SLAT AND HOLD WITH FINGER (FIGURE 13c). AVOID CROSSED STITCHES UNDER SLAT.
4. REMOVE SLACK BY PULLING UP AND TO THE RIGHT. KEEP LOOP ON TOP OF CABLE (FIGURE 13d).
5. TIGHTEN STITCH BY PULLING TO RIGHT AND DRAWING LOOP TO TOP FRONT OF CABLE. REMOVE SLACK AND TIGHTEN WITH A STEADY EVEN PULL (FIGURE 13e).
6. STITCH WILL BE FURTHER TIGHTENED WHEN SUCCEEDING STITCH IS TIGHTENED (FIGURE 13e).

Figure 13 - "KANSAS CITY" Stitch

Sewing Methods Starting Stitch

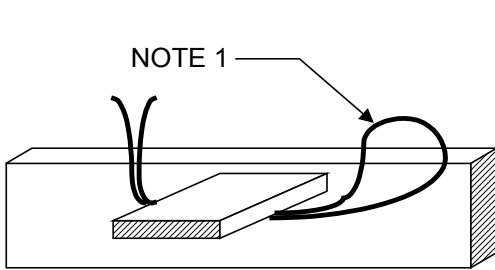

FIGURE 14a

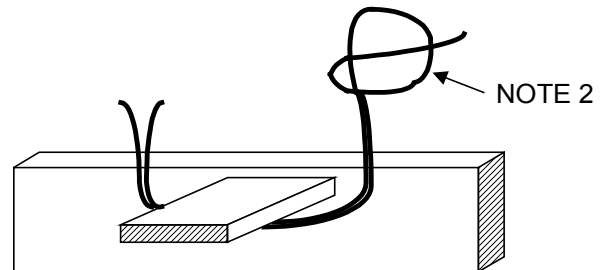

FIGURE 14b

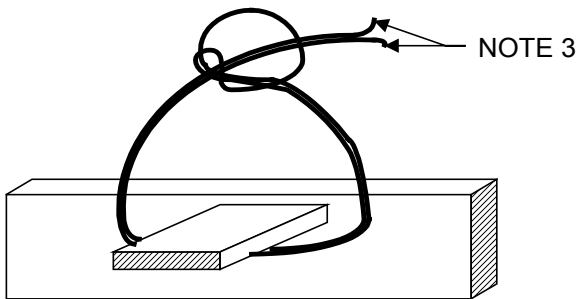

FIGURE 14c

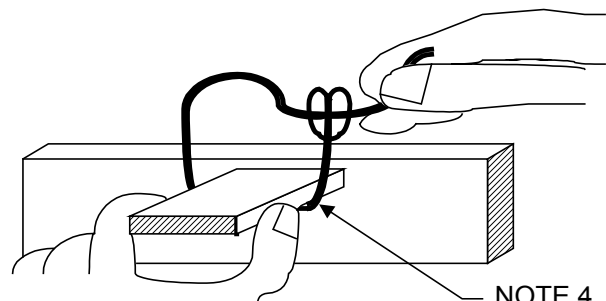

FIGURE 14d

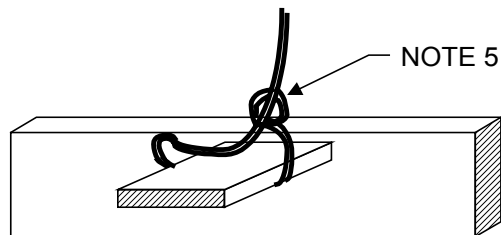

FIGURE 14e

NOTES:

1. DOUBLE A LENGTH OF LACING TWINE, EVEN UP THE ENDS AND PASS UNDER THE SLAT (FIGURE 14a).
2. DOUBLE LOOP END BACK ON ITSELF (FIGURE 14b).
3. PLACE FREE ENDS THROUGH LOOP (FIGURE 14c).
4. HOLD IN POSITION AND PULL OUT SLACK (FIGURE 14d). AVOID CROSSED STITCHES UNDER SLAT.
5. COMPLETED STITCH (FIGURE 14e). TIGHTEN SECURELY ON SLAT.

Figure 14. Starting Stitch

Sewing Methods Dead Ending Cable Stitches

DEAD-ENDING LARGE CABLE RUNS
"HAWTHORNE KNOT" ENDING STITCH

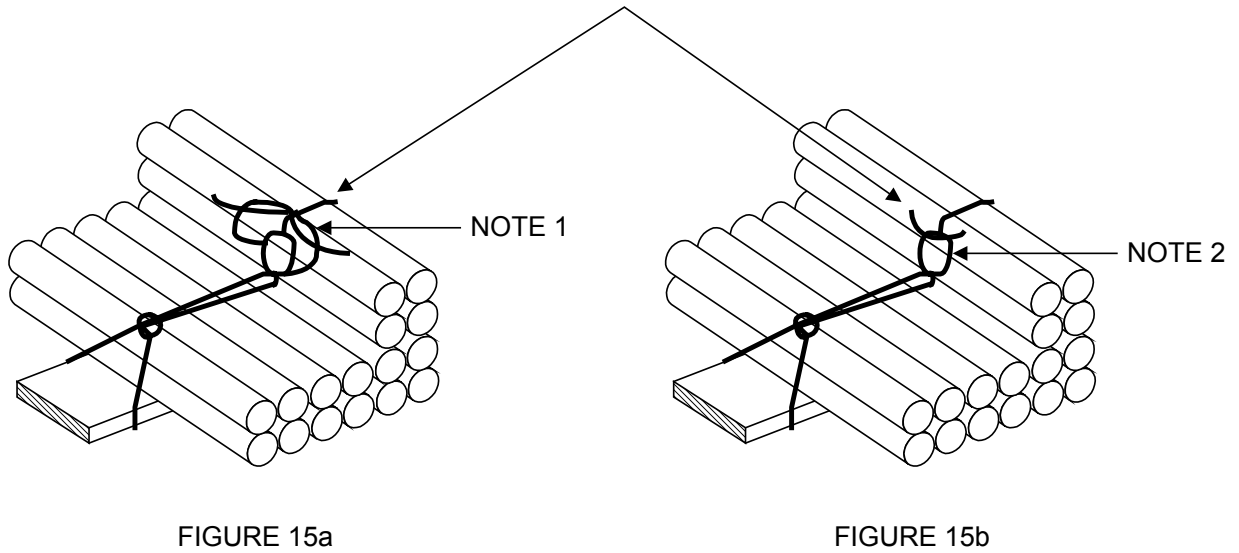

NOTES:

1. FORM KNOT AS SHOWN IN FIGURE 15a.
2. TIGHTEN KNOTS SECURELY AND CUT OFF ENDS OF TWINE AS SHOWN IN FIGURE 15b.

Figure 15. Dead-Ending Cable Stitches

Sewing Methods Second Layer Cable lacing

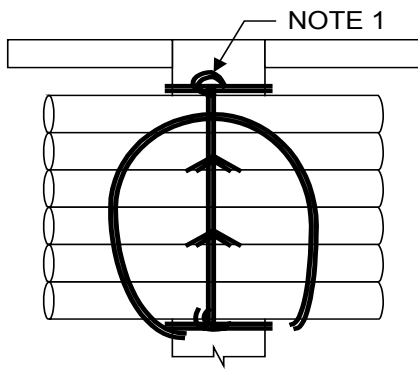

FIGURE 16a

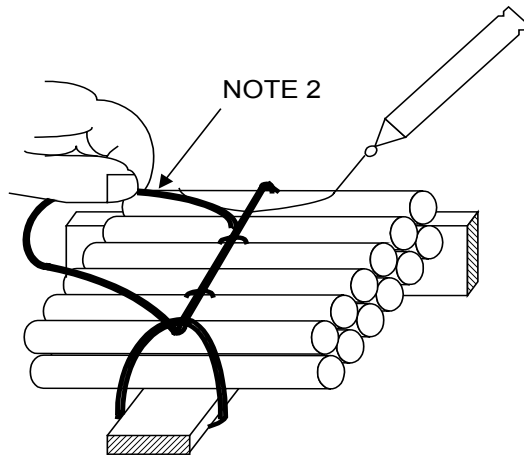

FIGURE 16b

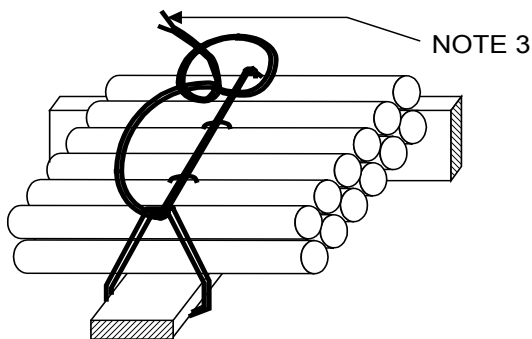

FIGURE 16c

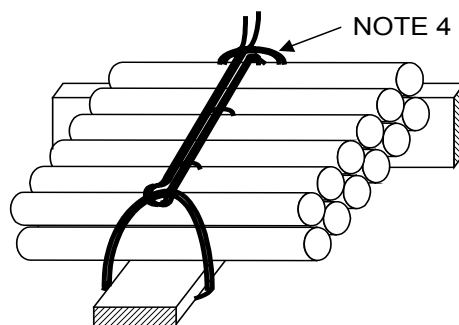

FIGURE 16d

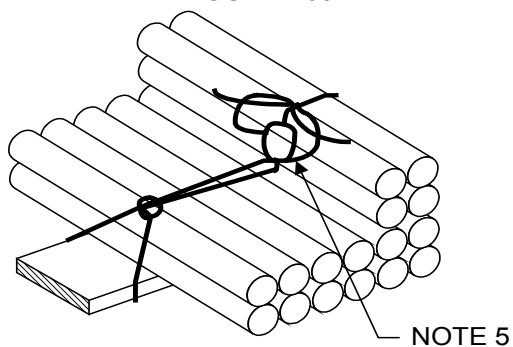

FIGURE 16e

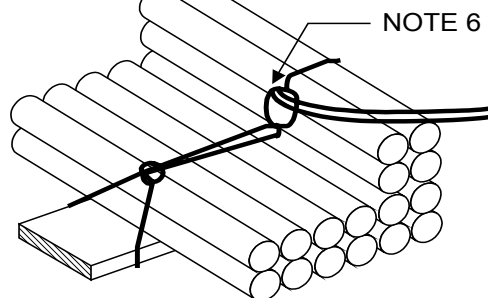

FIGURE 16f

NOTES:

1. KEEP STITCHES IN STRAIGHT LINE IN CENTER OF STRAP (FIGURE 16a).
2. PULL END OF TWINE UNDER FIRST STITCH WITH AN EVANS NEEDLE (FIGURE 16b).
3. LOOP END OVER TWINE AND BACK THROUGH LOOP (FIGURE 16c).
4. TIGHTEN KNOT OVER TOP OUTSIDE EDGE OF CABLE (FIGURE 16d).
5. MAKE "KANSAS CITY" STITCH THROUGH THE FIRST BOTTOM STITCH IN ACCORDANCE WITH FIGURE 16e.
6. TIGHTEN KNOT IN PREPARATION FOR SEWING NEXT GROUP OF CABLES OR DEAD END AS SHOWN IN FIGURE 16f.

Figure 16. Lacing Second Layer of Cable

Sewing Methods Splicing Single Strand Lace

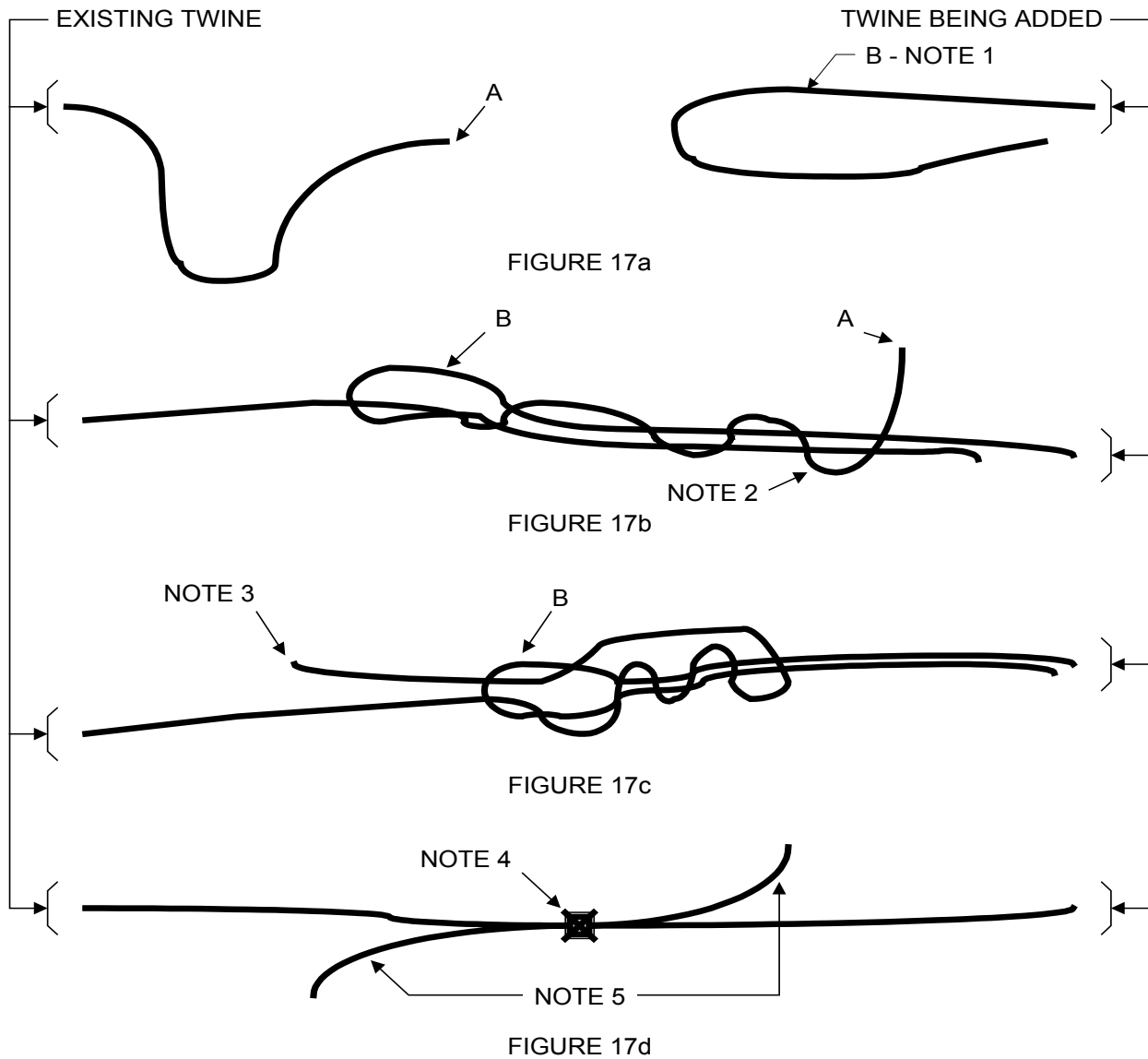

NOTES:

1. ON THE END OF THE TWINE BEING ADDED (LOOP B) MAKE A STARTING LOOP (FIGURE 17a).
2. PLACE THE END OF EXISTING TWINE "A" THROUGH THE LOOP AND WRAP AROUND LOOP "B" TWO TURNS (FIGURE 17b).
3. RETURN END "A" THROUGH LOOP "B" (FIGURE 17b AND 17c).
4. TIGHTEN THE KNOT BY PULLING BOTH ENDS (FIGURE 17c).
5. CUT OFF EXCESS TWINE AFTER TIGHTING THE KNOT (FIGURE 17d).

Figure 17 - SPLICING SINGLE STRAND LACING TWINE

Sewing Methods (Chicago/Kansas City, Etc.)

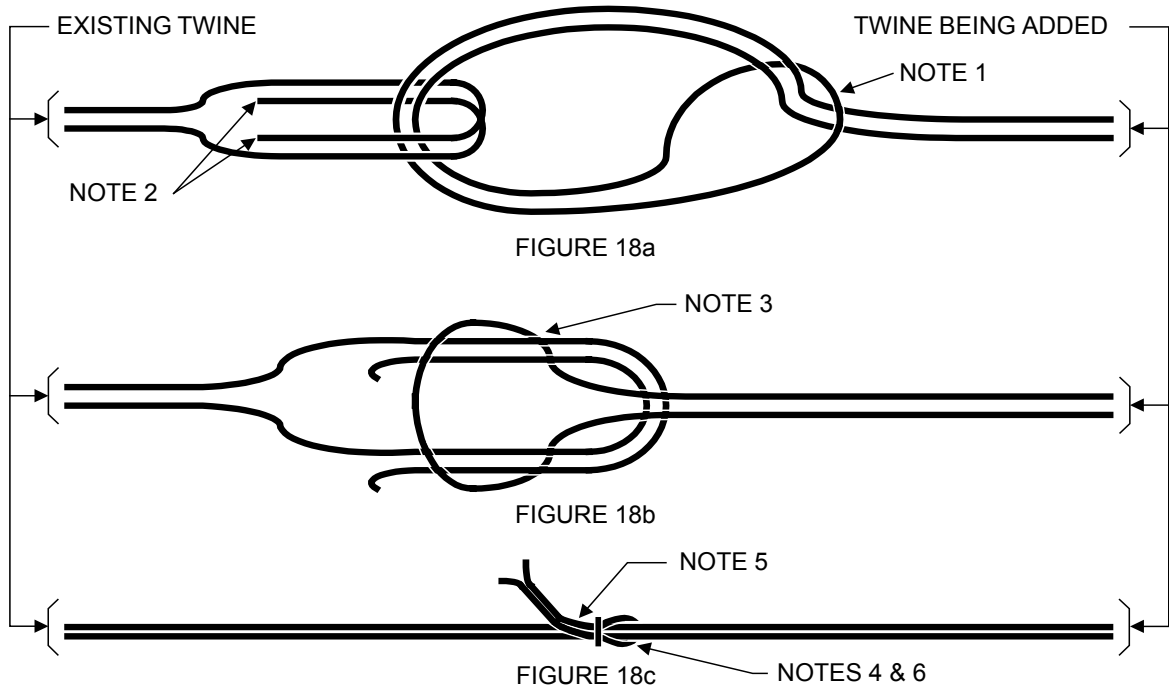

NOTES:

1. MAKE LOOP FOR STARTING STITCH IN TWINE BEING ADDED (FIGURE 18a).
2. PLACE EXISTING TWINE END THROUGH STARTING STITCH LOOP IN OPPOSITE DIRECTIONS (FIGURE 18a).
3. SLIDE LOOP OF STARTING STITCH BACK OVER EXISTING TWINE (FIGURE 18b).
4. TIGHTEN THE KNOT (FIGURE 18c).
5. CUT OFF EXCESS TWINE AFTER TIGHTING (FIGURE 18c).
6. WHEN LACING CABLE, PLACE THE KNOT AS CLOSE TO THE CABLE BEING LACED AS POSSIBLE SO IT WILL NOT INTERFERE WITH LACING THE SUCCEEDING CABLES (FIGURE 18c).

Splicing Double Strand Lacing Twine.

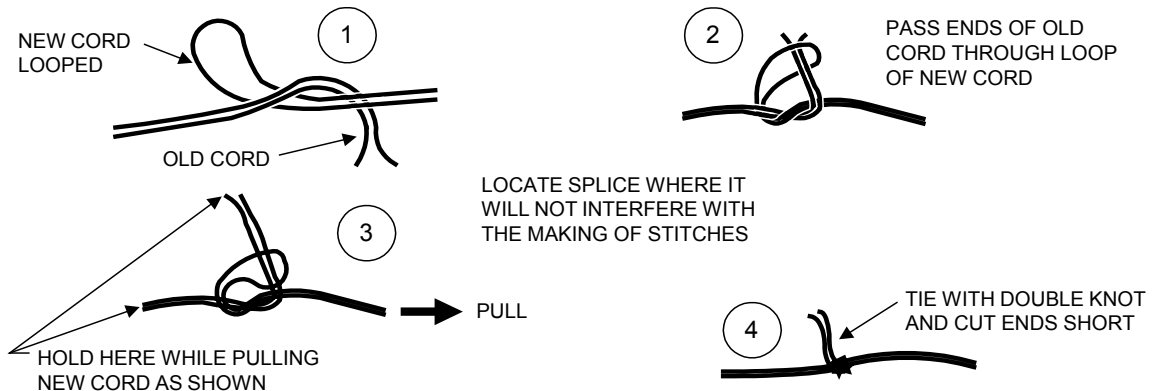

Figure 18 - A METHOD OF SPLICING DOUBLE STRAND CORD

Sewing Methods Securing Cables to Ladder Rack Support

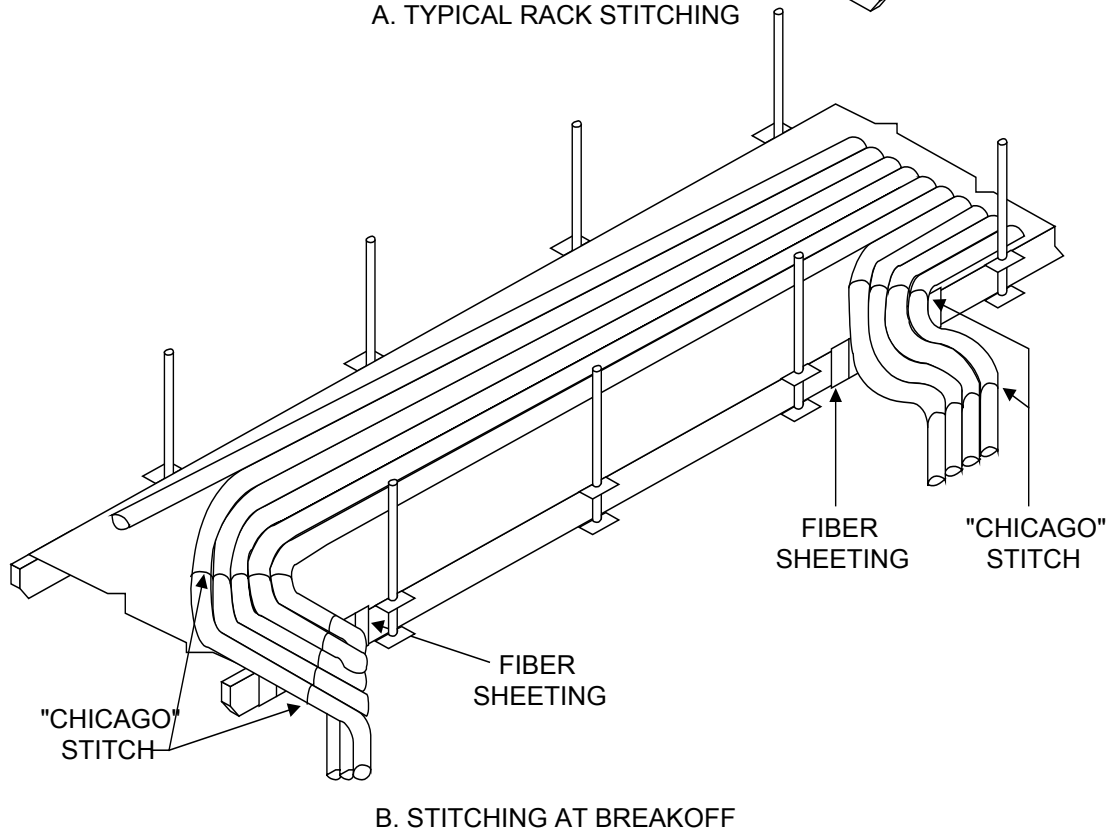
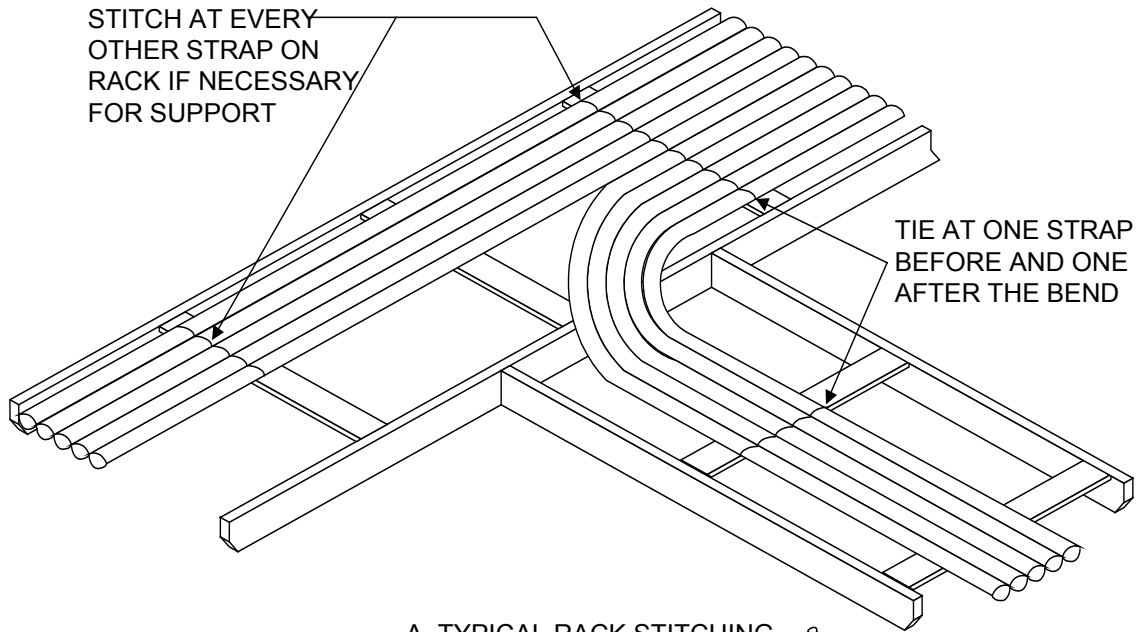

Figure 19 - SECURING CABLES TO HORIZONTAL RACKS